



DOTRA'S.....DotLine.....

ISSUE NO. 99

MAY 2017

A Publication of the New Jersey Department of Transportation Retirees Association Inc.

PRESIDENT'S REPORT

By Clint Griggs

During the last few weeks the DOTRA Family has been saddened by the loss of two members of our Board of Directors; Art Egan, a current Director and John "Jack" Mansfield, a former board member. The thoughts and prayers of the entire DOTRA organization are with their families at this special time. Both will be sorely missed.

Hopefully, we have seen the last of winter 2017! For the first time in DOTRA history we were forced to postpone and reschedule our "Spring" Breakfast event at the Golden Dawn Restaurant due to the March snow storm. In spite of the reschedule, we happily entertained 49 DOTRA members and guests, including some new faces. A great time was had by all. Our thanks go out to Joe Bodner for another great event. Just a reminder that in the event a cancellation should occur in the future, we will post the latest info on our DOTRA website as soon as we become aware of the cancellation.

In this DOTLINE you will find information on upcoming events; next is our Anniversary Luncheon in June. We are also working on our September Picnic and our Holiday Gala in December. DOTRA trips are also back under discussion. More on those as plans materialize.

Lastly, after many failed attempts, we finally convinced the DOT to provide DOTRA the names of recent retirees. We only receive names, but that's a start! Again, if you know of a DOT'er ready to retire, please pass their name along to one of our Directors, or recruit them on your own.

HAPPY SPRING!

Our mailing address:
DOTRA
PO BOX 77160
WEST TRENTON, NJ 08628

UPCOMING EVENTS

June Luncheon
June 13, 2017 @ 12 Noon to 3:00 PM
Erini's, 1140 River Road, Ewing, NJ 08628

Annual DOTRA Picnic
September 13, 2017
Mercer County Valley Road Picnic Grounds

DOTRA BOARD MONTHLY MEETINGS

DOTRA continues to hold its regular monthly meetings on the first Tuesday of each month. All are invited to attend. Hope to see you there. Our next meeting will be held on **Tuesday – June 6, 2017 at 11 AM at Tessara's Restaurant, 812 Route 33, Hamilton Twp.** Our business meeting starts at 11 AM followed by a Dutch-treat luncheon. **Please note that there is no meeting scheduled for July.** Schedule of future meetings at Tessara's:

- Tuesday, August 1, 2017
- Tuesday, September 5, 2017
- October 3, 2017

DOTRA ON THE INTERNET!!

You can read the current issue of the DOTLINE on the Website - as well as check back issues!!!
Log onto DOTRA's own Web Site:
<http://www.dotra.org>

2017 DUES were due January 1, 2017!!!

**If you haven't paid your 2017 dues yet,
please do so NOW!!!**

Check your Mailing Label to see if you are paid up for 2017!! Electronic "mailers" have been notified by e-mail! Don't forget to notify DOTRA if you have a change of address. This is especially important for Life members and those who receive DOTLINE electronically.

DOTLINE ELECTRONICALLY

If you are willing to receive your DOTLINE via electronic mailing, please submit your email address to us at:

DOTRAexpress@yahoo.com

The Transporter is now available to retirees on the DOTRA website at <http://www.dotra.org>, with the 2011, 2012, 2013, and 2016 issues already posted. Future issues will be posted on a quarterly basis.

DOTRA EXECUTIVE BOARD & OFFICERS

PRESIDENT	Clint Griggs	609-888-0115
1st VP	Jay Johnston	609-588-0930
2nd VP	Gerry Sellner	609-737-1665
TREASURER	Lou Papp	609-585-7697
ASST. TREAS.	Frank Stia	609-882-3862
REC. SEC	Andrea Mansfield	609-890-9497
CORRES. SEC.	Donna Troiano	609-298-5962

DIRECTORS/TERM OF OFFICE

Joe Bodnar (17)	Frank Palise (17)
Janis Stia (17)	Frank Herrera (17)
Peter Yull (17)	Donna Troiano (18)
Dot Andres (18)	Gerry Sellner (18)
Mike Eckel (18)	John Rainiero (19)
Andrea Mansfield (19)	Lou Papp (19) Bruce
Strickland (19)	Bob Miller (19)
Jay Johnston (19)	Clinton Griggs (19)
Frank Stia (19)	

COMMITTEES

AUDIT	Frank Palise	609-896-2011
CHAPLAIN	Jay Johnson	609-588-0930
MEMBERSHIP	Janis Stia	609-882-3862
BY-LAWS	Vacant	xxx-xxx-xxxx
HISTORIAN	Mike Eckel	609-499-9225
ACTIVITIES	Vacant	xxx-xxx-xxxx
DOTLINE	Frank Palise	609-896-2011
DATABASE	Gerry Sellner	609-737-1665
WEBSITE	Bruce Strickland	505-847-3300
DOT MEMORIAL	Jim Dixon	609-298-3398
NOMINATING	Joe Bodnar	609-298-6260

Directors Emeritus

Adrian Lincoln, Margaret "Peg" Wieger, Hazel Rockhill, Phil Vecere, and Chet Andres

MEMBERSHIP REPORT

By Janis Stia

During the last three months, the following new members have joined DOTRA:

Buckley, Debra	Region, Operations-Central
Buckley, Donald	Region, Operations-South
Lovett, Fredrick	Materials
Tobin, Marty	Bridge

CHAPLIN'S REPORT

By Jay Johnston

We would like to be informed about any retiree who has passed away, is ill, confined to their home, in a rehabilitation center, or needs help in one way or another. Please send any information to me at:

3 Golden Crest Court, Hamilton N.J. 08691

Phone: 609-588-0930

E-mail: jay050645@yahoo.com

RECENT OBITUARIES

John "Jack" Mansfield*	72
Arthur Egan Jr.*	72
James "Jamie" Fox	62
Thomas Cochran	80
Gloria Allen *	90
John " Jack" Wouters	99
Phillip Bertucci	64
Clifford Heckman*	76

* Denotes DOTRA Member

FLORIDA REUNION

By Stef Franklin

The Florida contingent of DOTRA held its annual Luncheon at Harry's Restaurant in St. Augustine on February 14, 2017. Although it was a small attendance (only 17 people attended), we all had a lot of fun. Gail and Tony Gelak came all the way from Lehigh Acres (Ft. Myers) they stayed for a couple of days and enjoyed the sites of St. Augustine. Next year we are looking to have the luncheon in or around Cape Canaveral on **the second Tuesday in February 2018**. Plan to be there next year!



From left to right

Anne & Charlie Takas, Gail & Tony Gelak, Kathy & Frank Wegel, Liz & Martyn Tobin, Dot Andres, Cindy Franklin, Kathy & Keith Swango, Rich & Connie Sawicki, Stef Franklin, Jimmy Avillo & wife

DOTRA TRIPS

By Jay Johnston

The following trips are being planned:

ROCKETTES CHRISTMAS TRIP

Radio City Music Hall
Around December 6th 2017

DOOLAN'S SHORE CLUB TRIP

Spring Lake, NJ
Fall, 2017

More details in future newsletters!

JERSEY BARRIER

By Mike Eckel

A **Jersey barrier** or **Jersey wall** is a modular concrete barrier employed to separate lanes of traffic. It is designed to minimize vehicle damage in cases of incidental contact while still preventing the crossover case of a head-on collision. Jersey barriers are also used to reroute traffic and protect pedestrians and workers during highway construction, as well as temporary and semi-permanent protections against land borne attack such as suicide vehicle bombs. A Jersey barrier is also known in the western United States as **K-rail**, a term borrowed from the California Department of Transportation specification for temporary concrete traffic barriers, or colloquially as a **Jersey bump**.

The Jersey barrier, also called New Jersey wall, was developed in the 1950s (introduced in current form in 1959), at the Stevens Institute of Technology, New Jersey, United States, under the direction of the New Jersey State Highway Department to divide multiple lanes on a highway. A typical Jersey barrier stands 32 inches (81 cm) tall and is made of steel-reinforced poured concrete. Many are constructed with the embedded steel reinforcement protruding from each end, allowing them to be incorporated into permanent emplacements when linked to one another by sections of fresh concrete poured on-site.

Their widespread use in road construction has led to wide application as a generic, portable barrier during construction projects and temporary rerouting of traffic into stopgap carpool and rush-hour reversing highway lanes.

The design of the Jersey barrier was specifically intended to minimize damage in incidental accidents and reduce the likelihood of a car crossing into oncoming lanes in the event of a collision. In common shallow-angle hits, sheet-metal damage is minimized by allowing the vehicle tires to ride up on the lower sloped face. Head-on collisions are minimized by gradually lifting the vehicle and pivoting it away from oncoming vehicles and back into traffic heading in its original direction.

Modern variations include the constant-slope barrier and the F-shape barrier. The F-shape is generally similar to the Jersey barrier in appearance, but is taller, with somewhat different angles. The UK equivalent is the concrete step barrier.

First tested in 1968 by the then Department of Highways in Ontario, Canada, the **Ontario Tall Wall** is a variant of the Jersey barrier. Standing at 42 inches (107 cm), it is 10 inches (25 cm) taller than the standard Jersey barrier. In Ontario, the Ministry of Transportation is replacing guiderails (steel guardrail and steel box-beam) with these barriers on 400-series highways.

The New Jersey Turnpike Authority developed and tested a similar, but heavily reinforced, design. This barrier design has been credited with effectively containing and redirecting larger vehicles, including semi-trailer (tractor-trailer) trucks. The states of New York, Massachusetts, and New Jersey have adopted the taller barrier for their roads, as compared to the standard 32 inches (81 cm) suggested by the Federal Highway Administration.

Designs with two rectangular notches at the bottom (through the short axis) allow for forklift-style lifting by front-end loaders. Barriers meant for short-term placement, especially in military and security barrier uses, might include steel rebar loops embedded in the top surface for rapid hook-and-cable system lifting.

The 2010 G-20 Toronto summit used a modified modular Jersey barriers with wired fencing bolted onto the concrete. The fence used the barrier as sturdy base to prevent protesters from toppling the fence around the security zone at the Metro Toronto Convention Centre.

The U.S. military nicknamed the devices as "Qaddafi Blocks" after truck bomb attacks in Beirut in 1983 resulted in more widespread use in military installations. Sometimes they are deployed to form a chicane to slow vehicular traffic arriving at military installations or other secure areas.

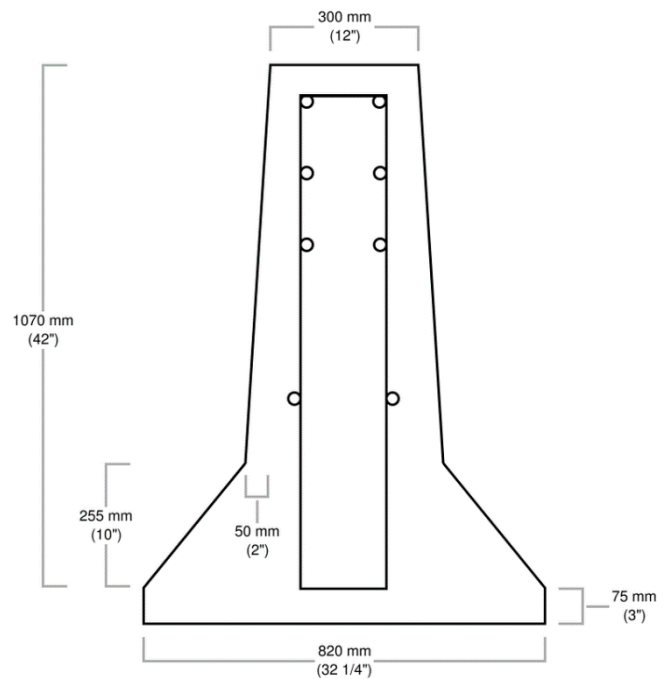

DOTRA PROJECT OUT REACH **CONTACTING OUR MEMBERS**

By Dot Andres

Since DOTRA Directors began making phone calls to people on the DOTRA Membership List, we have heard from a few people who took the initiative to give one of the DOTRA Directors a phone call. What a surprise one evening in warm Florida when my Phone Message center said a call from Vermont was coming in. It was **Alan Nass**-who can forget the **Region 1 Maintenance** guy who worked in Permits and Engineering way back when.

Alan was calling to remind DOTRA that he had moved South from Maine to a warmer friendlier climate in Vermont - closer to civilization. Alan is doing well; kids are located nearby in Vermont. Still hunts and doing the outdoor things he's loved. Sends regards to those who may still remember him. How can we forget Alan Nass!

Got another phone call from **Ellen McCourt** searching for info on a fellow DOTRA member who was an alumnus and went to Waynesboro College. Ellen is well and still very active travelling with partner Steve. Spent short visit to St. Augustine, FL this winter.

Speaking of St. Augustine, received a phone call in February from **Jim Avilla - Design/Newark** office wanting info on the DOTRA FLORIDA Reunion. Jim and wife were there for a vacation and able to make the DOTRA Reunion – surprising **Steffan Franklin** and attendees. Speaking of the Florida Reunion, Steffan Franklin did a great job organizing and planning the annual winter event held at a historic eating place in old Saint Augustine.

DOTRA has an AUTHOR!!

Do you remember **Kate Immordino**?? Leaving the NJDOT in 2006 as an Assistant Commissioner for Administration after starting out with Construction and Maintenance, Kate ventured on to other career tasks in NJ State government. Now Kate has published a book – a mystery titled “**DOUBLE IMAGE**”, available as a paperback and e-book on Amazon.com and Barnes and Noble. Read the great article about Kate’s book - featured at the end of this issue of the DOTLINE. Kate’s husband **Howard** is also a DOTRA member, working many years in the finance and planning areas of the NJDOT and retiring from the Capital Strategies Bureau. Kate and Howard have 2 children, Matt and Jackie, and “two beautiful grandsons.”

How about some more news from you DOTRA Members out there? We want to hear from you!

**DON'T WAIT FOR US TO CALL YOU.
CONTACT US WITH YOUR NEWS!!!**

**SEND TO DOTRA E-MAIL ADDRESS:
DOTRAexpress@yahoo.com
or call:
Dot Andres @ 386-426-5356
or
Clinton Griggs @ 609-888-0115**

NJDOT EMPLOYEE MEMORIAL COMMITTEE MAY 2017 REPORT **By Jim Dixon**

There was no meeting held in April due to a conflict with Take Your Children to Work Day. The Employee Memorial Committee is continuing its activities with new members recruited to fill positions by retiring DOT employees.

The Memorial Site has just had the new lighting project completed by DOT Maintenance. The landscape clean-up

project done by the Committee was proposed for April, 2017.

On April 12, 2017, the Committee sold 40 Easter Baskets and 75 Easter Flowers for a successful fund raiser. There will be a Mother’s Day Flower Sale at 10AM on May 11, 2017 outside the E&O Building.

The Annual September 9/11 Remembrance Event will be held on Monday September 11, 2017. There is a plan to honor, recently deceased, former DOT Commissioner Jamie Fox with a Plaque for his support of the EMC.

DOTRA’s Author – Kate Immordino

DOUBLE IMAGE -The book is written under the pen name **Kate Francis**.

“I started writing the book about 5 years ago, and it’s been in my mind for much longer than that. I would work on it, mostly in the summer, and had a great group of pre-readers including DOT retirees **Judy Semler**, who would give me feedback.”

The book is set in Mercer County, including Trenton, Princeton, Ewing and Washington Crossing State Park. It’s about a NJ State Trooper named Kenna Devlin, who is part of the Executive Protection unit assigned to guard the Governor and his family.

As the newest member of the unit, she’s often assigned to protect the Governor’s 10-month old son. She wishes for a more challenging assignment until the day the baby is kidnapped while under her care. When he’s found unharmed, two days later, no one is happier than Kenna. That is, until she receives information that suggests the child they found is not the same one who was taken.

Unsure who to trust, she works with a skeptical FBI agent and the alleged kidnapper to try to find a connection with the Governor’s decision to run for Vice President!

Kate is interested in speaking at book groups and is so grateful that people are reading and enjoying it. She is currently working on a sequel.

Kate plans to attend our June luncheon and would be happy to talk about the book. So, let’s come out and show her our support for her new career as an author!

LAST WORD...You have the last word. Maybe someday you will tell us what it is....

MEMBERSHIP APPLICATION/RENEWALS

() **NEW** APPLICATION FOR DOTRA MEMBERSHIP - \$10.00/ YEAR _____
- \$75.00 LIFE MEMBERSHIP _____

(FILL IN FORM COMPLETELY)

() **RENEWAL** OF DOTRA MEMBERSHIP FOR YEAR _____ CHECK FOR \$10.00 ENCLOSED

() REQUEST FOR **LIFE MEMBERSHIP IN DOTRA** _____ CHECK FOR \$75.00 IS ENCLOSED
(Converting from annual membership)

() **CHANGE OF ADDRESS** (FILL IN NAME ADDRESS,-both snail mail and email, AND TELEPHONE NUMBER)

() PLEASE ADD **YOUR COMMENTS** FOR INCLUSION IN AN UPCOMING DOTLINE.

NAME: _____ **TELEPHONE:** _____

STREET/ PO BOX: _____ **E-MAIL:** _____

TOWN/ CITY: _____ **COUNTY** _____ **STATE** _____ **ZIP** _____

EMAIL ADDRESS: _____

FORMER UNIT WITHIN NJDOT: _____ **YEARS WORKED** _____ **YEAR RETIRED** _____

I WOULD LIKE TO WORK ON A DOTRA COMMITTEE _____

COMMENTS: _____

Send Application and Check to: "DOTRA" – PO BOX 77160, WEST TRENTON, NJ 08628

NEW JERSEY DEPARTMENT OF TRANSPORTATION RETIREES ASSOCIATION